

SERVICE

HDF1201/4-1F-1H

HDF1201/4-2F-2H

Thank you for choosing a Hydrotech filter.

It is a trustworthy machine that will run for a long time with minimum care and service. Indeed, any mechanical equipment requires annual maintenance in order to operate efficiently and with as little down time as possible. This is also the case with your Hydrotech Drumfilter HDF1200-1F or -2F.

On the next pages, you will find recommendations for maintenance, parts to change and drawings.

If you don't have the possibility to do the maintenance yourself, Hydrotech will be pleased to send you a service offer or recommend a reliable technician that can assist you.

Apart from the periodic maintenance mentioned in the **Operation & Maintenance manual** we recommend a large service every fifth year where at least all parts in the **5 year service kit** are replaced.

To order spare parts or a service from Hydrotech and also to get the latest updated prices, please contact Hydrotech at services@hydrotech.se.



Veolia Water Technologies AB

Hydrotech

Mejselgatan 6, 235 32 Vellinge, Sweden
Phone +46 40 42 95 30, Fax. +46 40 42 95 31
mailbox@hydrotech.se
www.hydrotech.se



SERVICE

HDF1201/4-1F-1H

HDF1201/4-2F-2H

5 year service kit

Art. N°	N° on drawing	Description	Qty	Filter versions
424020	4828 pos.9	Key steel 12x8x45 mm	1	HDF1201-3
424030	4828 pos.9	Key steel 12x8x45 mm	1	HDF1204
425500	4828 pos.3	Slide bearing Ø40 (drum shaft)	2	HDF1201-3
425510	4828 pos.3	Slide bearing Ø50	2	HDF1204
1006088	4828 pos.8	Shaft sealing radial 40x62x7	2	HDF1201-3
1006089	4828 pos.8	Shaft sealing radial 50x62x7	2	HDF1204
425725	4828 pos.4	Spacer 80/41x5 mm	2	HDF1201-3
425730	4828 pos.4	Spacer 90/50x5 mm	2	HDF1204
352310	2408 pos.6	Grease nipple, M8x1mm	3	
1010967		Manometer 0-16 bar 1/4" SI	1	
See table 2	0678-C pos.5	Rubber lip for solids tray	1	
420130	On chain	Offset link 1"	1	
420120	On chain	Chain lock 1"	1	
1001270	1329 pos.9	Chain wheel Z=32 1" for cone	1	
1001273	4828 pos. 11	Cone to chain wheel 3020-Ø40	1	HDF1201-3
1001274	4828 pos. 11	Cone to chain wheel 3002- Ø50	1	HDF1204
1001492	1329 pos.8	Chain wheel 1" 10 Ø30	1	
422000	See manual page 34	Rubber lip seal HDF1200	1	
1003834	4662-A	Support wheel type 14	2	

Table 2

Filter type	Qty for Art. N° Rubber lip for solids tray
HDF1201	1000468
HDF1202	1000469
HDF1203	1000470
HDF1204	1005258

Parts only valid for 1F tank version:

Art. N°	N° on drawing	Description	Qty
276125	On spray bar	Hose, 25 mm	0,6
1014371	On spray bar	Hose clamp Pa-Ri 49mm 2343	2
1006283	1329 pos.10	Chain 1" Rex simplex	1

Veolia Water Technologies AB

Hydrotech



Mejselgatan 6, 235 32 Vellinge, Sweden
 Phone +46 40 42 95 30, Fax. +46 40 42 95 31
 mailbox@hydrotech.se
 www.hydrotech.se

SERVICE

HDF1201/4-1F-1H

HDF1201/4-2F-2H

Parts only valid for 2F frame version:

Art. N°	N° on drawing	Description	Qty
1006289	1329 pos.10	Chain 1" Rex simplex	1

Strategic spare parts

Art. N°	N° on drawing	Description	Qty	Versions
		Backwash nozzles	5 per segment	
		Filter panels	3 per segment	
278040		Cartridge for strainer	1	

Parts only valid for 1F/1H tank version:

Art. N°	N° on drawing	Description	Qty	Versions
1001925		Drive shaft	1	HDF1201-3
1001573		Drive shaft	1	HDF1204

Parts only valid for 2F/2H frame version:

Art. N°	N° on drawing	Description	Qty	Versions
1002060		Drive shaft	1	HDF1201-3
1002062		Drive shaft	1	HDF1204

Critical spare parts

Art. N°	N° on drawing	Description	Qty
		Backwash pump	1
	1329 pos.12	Drive gear/motor	1

Definitions:

5 year service kit:

Parts to be changed after 5 years of operation

Strategic spare parts:

Parts with short lead time (always on Hydrotech stock) which are vital for the operation of the unit.

Critical spare parts:

Parts with long lead time which are vital for the operation of the unit, contact Hydrotech for precise delivery time.

Veolia Water Technologies AB

Hydrotech



Mejselgatan 6, 235 32 Vellinge, Sweden
 Phone +46 40 42 95 30, Fax. +46 40 42 95 31
 mailbox@hydrotech.se
 www.hydrotech.se

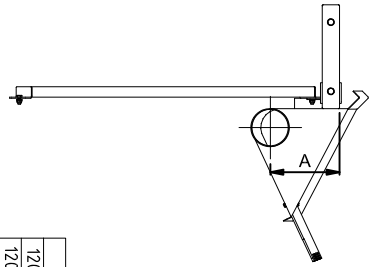

Type	A
1201-02 1,2,3H	138
1203-04 1,2,3H	14,5
1601-07 1H	180
1601-07 2,3H	200

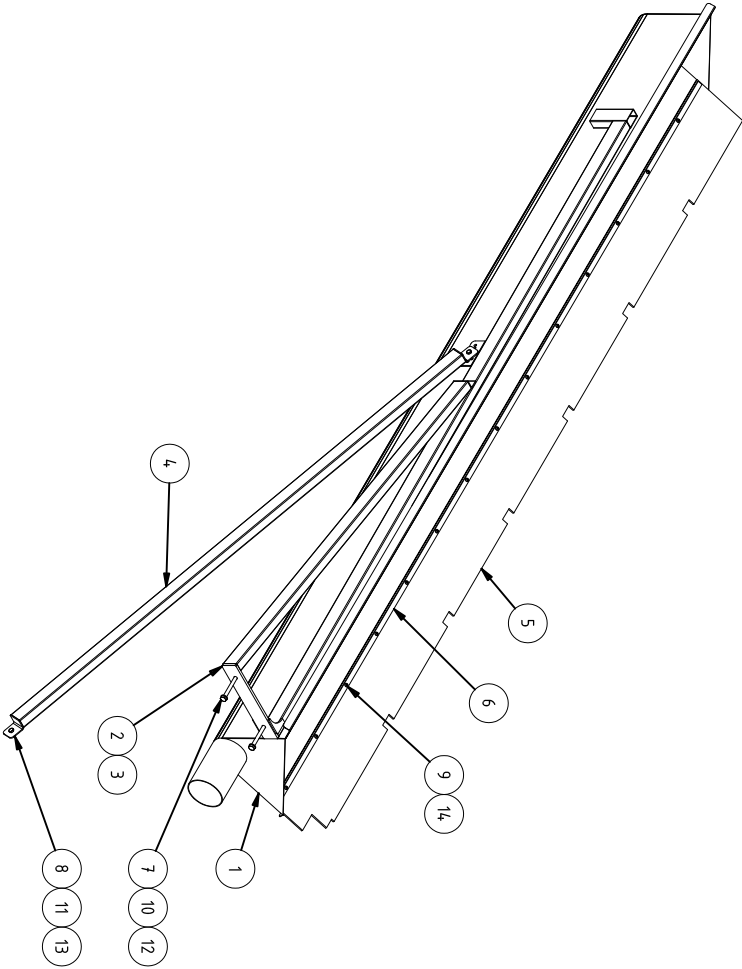
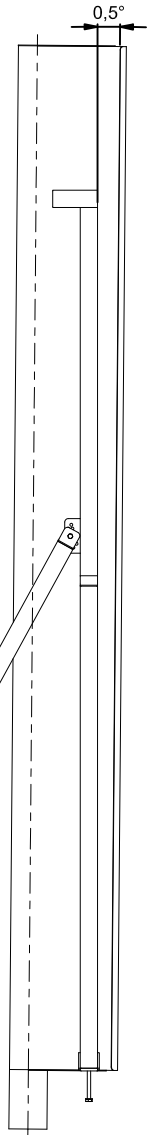

Type	B	C	D
12,1601	0	1	2
12,1602	0	1	4
12,1603	1	0	6
12,1604	1	0	8
1605	1	0	10
1606	1	0	12
1607	1	0	14

14	D	Nut locking	A4	M6NM M6	Art. no. 350310
13	2	Nut locking	A4	M6NM M8	Art. no. 350320
12	2	Nut locking	A4	M6NM M10	Art. no. 350330
11	2	Washer	A4	8,4x16x1,6	Art. no. 350540
10	4	Washer	A4	10,5x20x2	Art. no. 350550
9	D	Screw	A4	MRT M6x16H	Art. no. 1007487
8	2	Screw	A4	M6S M8x20H	Art. no. 350870
7	2	Screw	A4	M6S M10x100D	Art. no. 351017
6	1	Bracket for Rubber Lip	A4	t = 4	Drw. no. 0670
5	1	Rubber Lip for Solids Tray	Rubber	250 x 5	Drw. no. 5612
4	1	Strut for Solids Tray			Drw. no. 0685
3	C	Console for Solids Tray			Drw. no. 0676
2	B	Console for Solids Tray			Drw. no. 0677
1	1	Solids Tray			Drw. no. 0615

Pos no	Qty	Name	Material	Dimension	Remark
Designer	Drawn by	Projection method	Controlled by	Stand	Approved
DLS	DLS		ISO 2768-m	1 : 15	

HYDROTECH		Assembly Solids Tray		Scale	1 : 15
Drumfiller HDF1201-04		Drumfiller HDF1601-07		Sheet	1 / 1
0678		0678		Sheet size	A3
Edition		C		Released by	

Ed	Change and/or message no.	Rev date	Made by	Cm no.
C	Redrawn in Inventor - Updated.	2016-09-06	DLS	-

PROPERTY OF DRAWINGS AND PRESCRIPTIONS
 All property, rights and use remain to HYDROTECH AB, Sweden
 General conditions and use for this drawing is in accordance to ORGALIME S2000

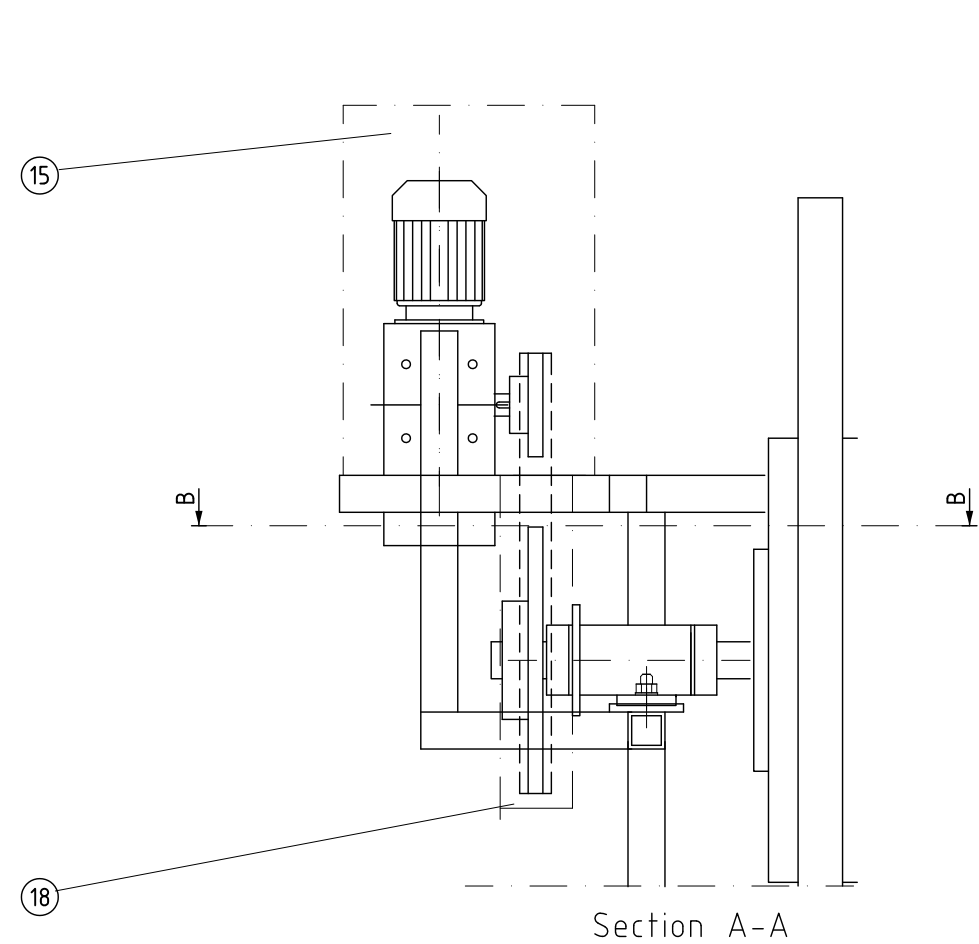

Section A-A

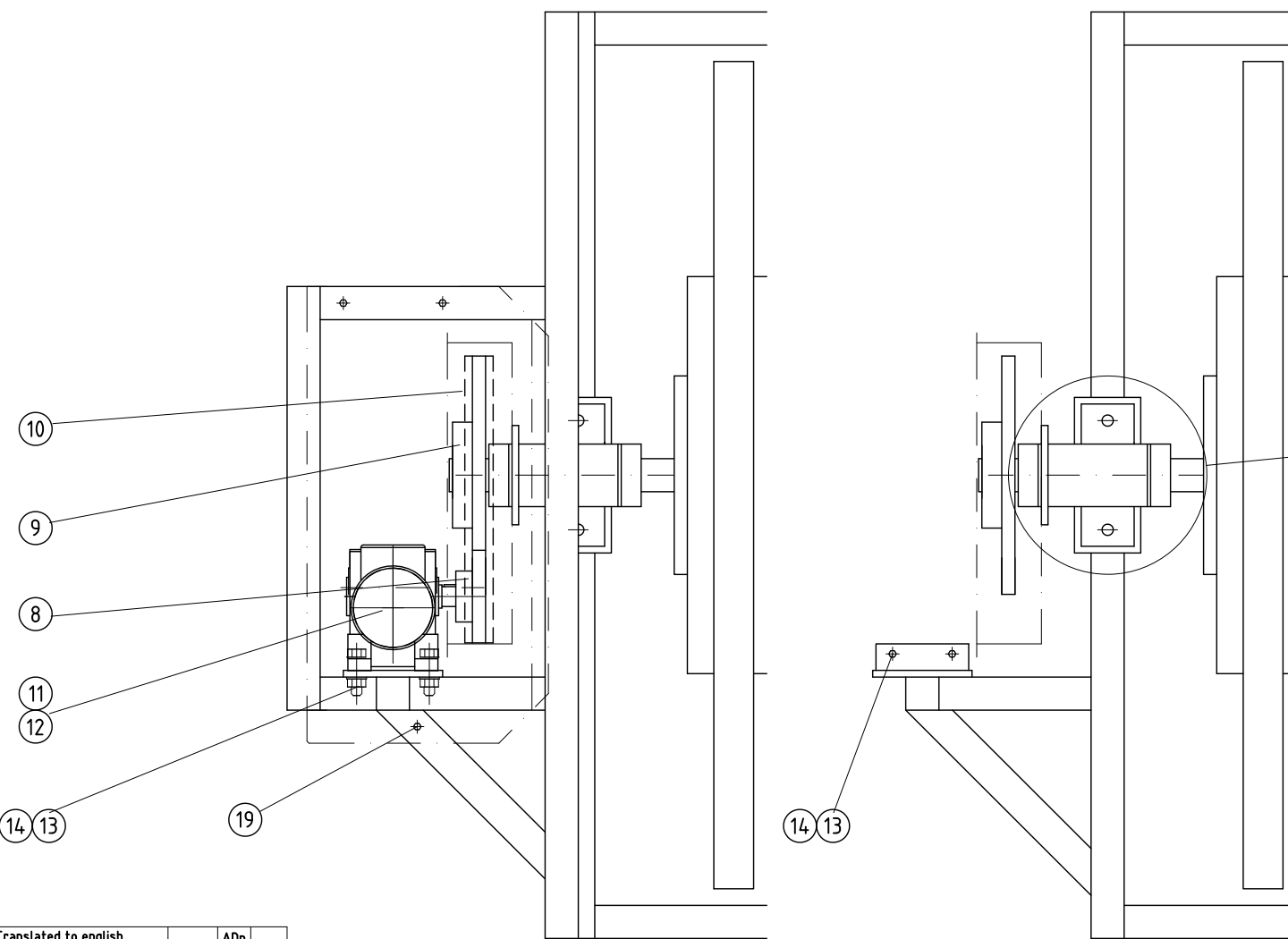
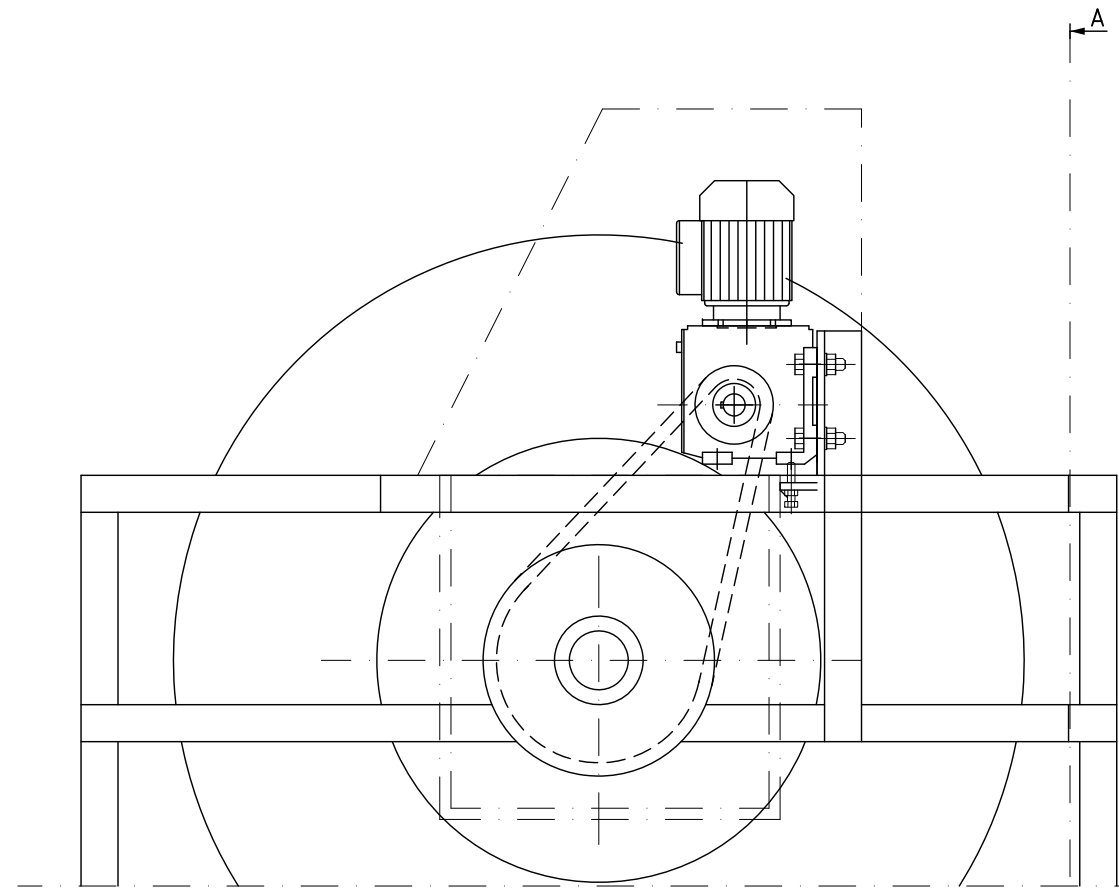

Section B-B

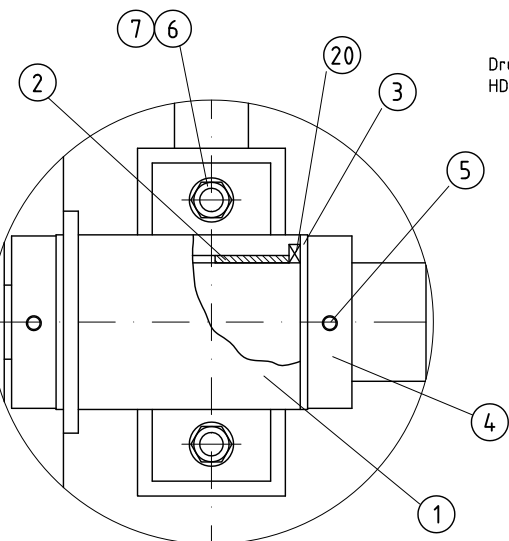

Drum filter
HDF 1201-03

Disc filter
HSF 1302-06

20	2	Radial sealing		Ø40xØ62x7	
19	7	Screw	SS2343	M6S 8x10	A4
18	1	Trough			Drw.No. 1141
17	2	Nut	SS2343	M6M M10	A4
16	2	Screw	SS2343	M6S 10x50	A4
15	1	Motor cover			Drw. No.1330
14	4	Nut		M6M M10	A4
13	4	Screw		M6S 10x20	A4
12	1	Motor 0.37 kW			SEW 52, DT63
11	1	Driving shaft			Drw. No. 0718-3
10	1	Chain		1"	
9	1	Sprocket		1" 32 teeth	
8	1	Sprocket		1" 11 teeth	
7	2	Washer	SS2343	BRB17x30x3A4	
6	2	Nut	SS2343	M6M M16	A4
5	6	Stop Screw	SS2343	SK6SS 8x20A4	
4	2	Retaining ring		Type 40	Drw. No.0674-4
3	2	Washer	Acetal	Ø41xØ80x5	Art.Nr.42 57 25
2	2	Bushing D40	Colly	Company ABA	Art.Nr. 42 55 00
1	1	Bearing house			Drw. No 1138

20	2	Radial sealing		62/50-7	
19	6	Screw	SS2343	M6S 6x10	
18	1	Trough			Drw. No. 1141
17	2	Nut	SS2343	M10	
16	2	Screw	SS2343	M6S 10x50	
15	1	Motor cover			Drw. No 1330
14	4	Nut			
13	4	Screw			
12	1	Motor			
11	1	Driving shaft			
10	1	Chain		1"	
9	1	Sprocket		1" 32 teeth	
8	1	Sprocket		1" 11 teeth	
7	2	Washer	SS2343		
6	2	Nut		M10	
5	6	Stop screw	SS2343	M10	
4	2	Reaining ring			Drw. No. 0579-4
3	2	Bushing			Drw. No. 0580-4 pos.1
2	2	Bushing			Drw. No. 0580-4 pos.2
1	1	Bearing house			Drw. No. 1139

Translated to english		ADn
1	Mafr.lista för 1201-03 fillk.	980522 ADn
Ed.	Change and/or message no.	Date Made by c-m no.

Part no.	Quantity	Name	Material	Std. or Blank	Dimension	Remark
AM	AM	Copy	Controlled by	Stand.	ISO 2768-m	Approved
					Scale	1:5
DESIGNER		HYDROTECH		Ass'y drive Type 2-3		Replaces
DRAWN		HYDROTECH		Drum Filter HDF 1200		Replaced by
CHECKED		HYDROTECH		Disc Filter HDF 1300		Date
APPROVED		HYDROTECH				971017
						Drw. no.
						1329

PROPERTY OF DRAWINGS AND PRESCRIPTIONS

All property, rights and use remain to **HYDROTECH** AB, Sweden

General conditions and use for this drawing is in accordance to ORGALIME S2000

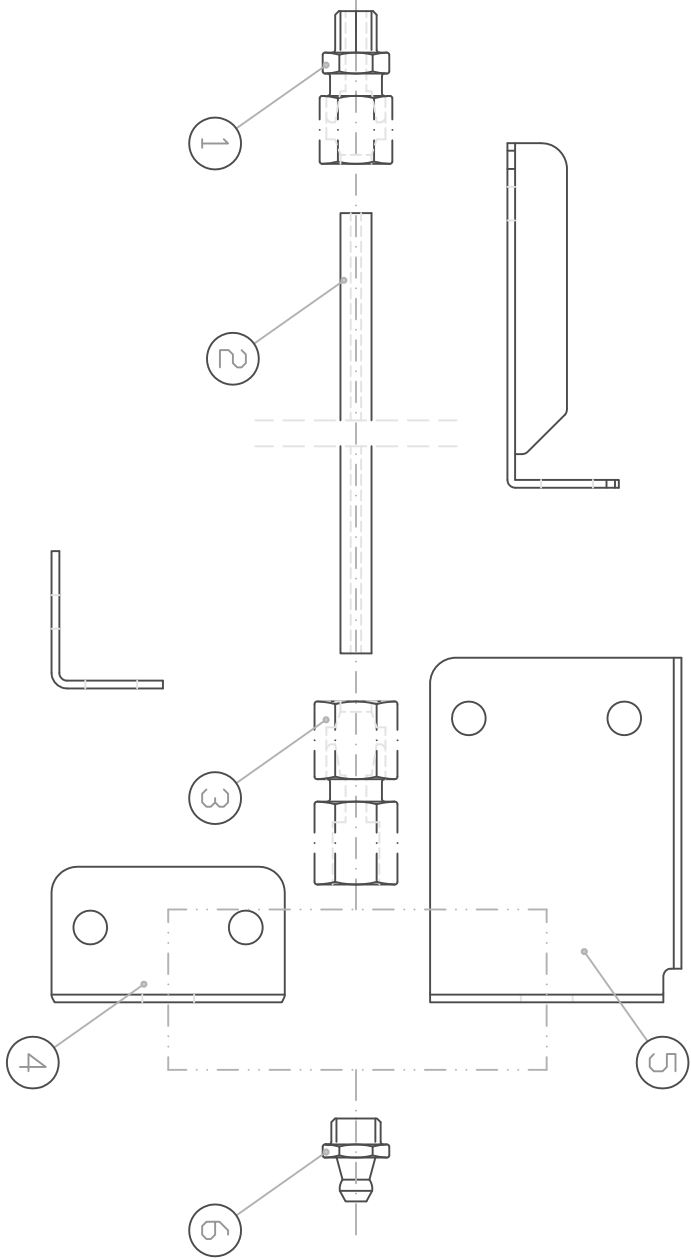

Edl Change and/or message no. Date Made by: -m no

Part no.	Quantity	Name	Material	Mod.-nr	Blank Dimension	Remark
1	1	Zirk fitting	AISI 316L			GE 6-LLM M8x1 SY
2	1	Hose	Polyamid	∅6		P 06 01 30
3	1	Angular zirk fitting	AISI 316L			GAI 6 LR SY(G1/8")
3	1	Zirk fitting	AISI 316L			90° (G1/8")
4	1	Holder	AISI 316L			Draw. 2405 pos 1
5	1	Holder	AISI 316L			Draw. 2405 pos 2
6	1	Greasing nipple	AISI 316L	G1/8"		H1-KR 1/8" SY

Designer	Drawn by	Copy	Controlled by	Stand.	Approved	Scale	Relates	Replaced by
	Per			ISO 2768-m		1:1	Grease fitting	

Drawn by	Date
JG	011017

Drawn by	Date	Edition
JG	24.08	A

HYDROTECH

Grease fitting
Rollerbearing housing

PROPERTY OF DRAWINGS AND PRESCRIPTIONS

All property rights and use remain to HYDROTECH AB Sweden

General conditions and use for this drawing is in accordance to ORGALIME S2000

Ed.	Change and/or message no.	Date	Made by	c-m no.
-----	---------------------------	------	---------	---------

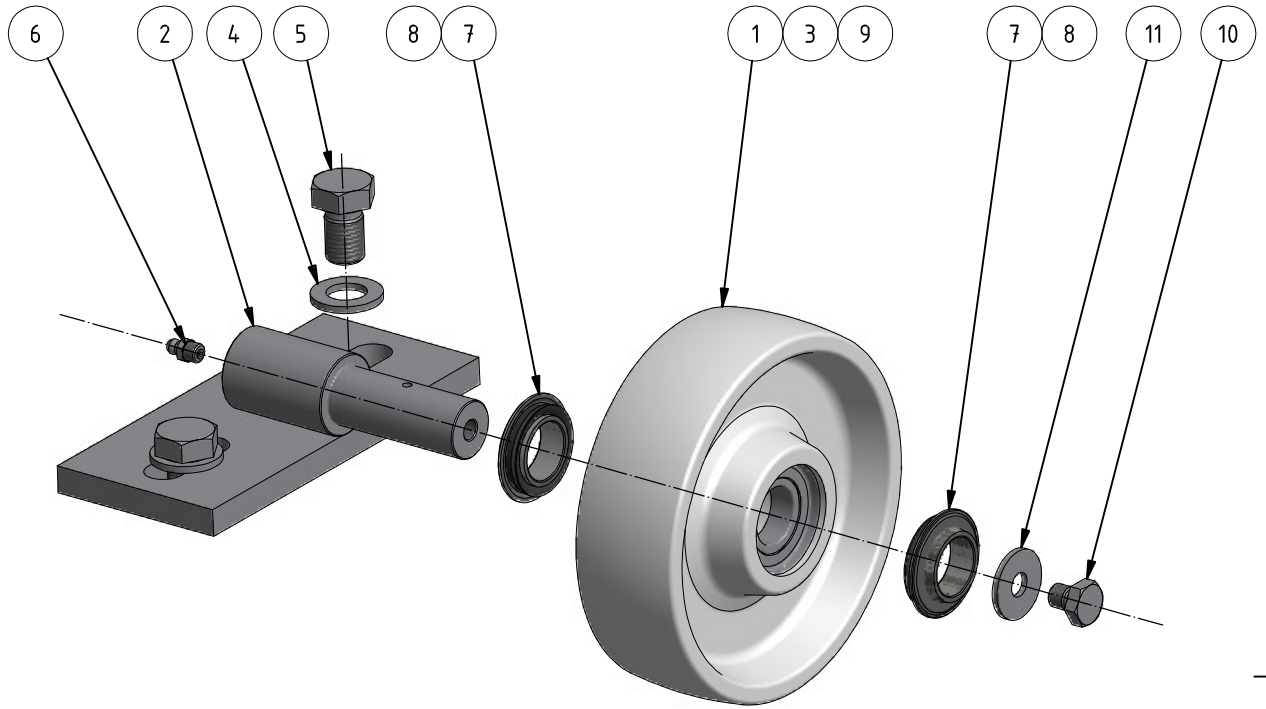

	A	B
HDF 801-3 1G	M12 x 70	13x24x2.5
HDF 1201-04	M12 x 30	13x24x2.5
HDF 1601-04	M16 x 30	17x30x3

Part no.	Qty	Name	Material	Mod.-nr Blank Dimension Mass	Remark
11	1	Washer	A4	RB 10,5x30x2,5	Art.no. 350552
10	1	Bolt	A4	M6S M10x12	Art.no. 1014331
9	2	Support for radial sealing	AISI 316L		Colson (Art.no. 1001606)
8	2	Radial sealing	Rubber		Colson (Art.no. 1001606)
7	2	Support for radial sealing	Plastic, Black		Colson (Art.no. 1001606)
6	1	Grease Nipple	AISI 316L	M8x1	Art.no. 352310
5	2	Bolt	A4	M6S A	
4	2	Washer	A4	RB ØB	
3	2	Ball bearing	AISI 304	6005	Colson (Art.no. 1001606)
2	1	Bearing bracket			Drw. no. 2380
1	1	Support wheel	Plastic, White	160 x 50	Colson (Art.no. 1001606)

Designer EmS	Drawn by EmS	Copy	Controlled by	Stand. ISO 2768-m	Approved	Scale	Replaces	Replaced by
HYDROTECH Support Wheel unit Exploded view Drumfilter HDF 800-1G, 1200, 1601-4							Date 2011-04-12	
							Draw. no. 4662 Edition A	

PROPERTY OF DRAWINGS AND PRESCRIPTIONS

All property rights and use remain to HYDROTECH AB Sweden

General conditions and use for this drawing is in accordance to ORGALIME S2000

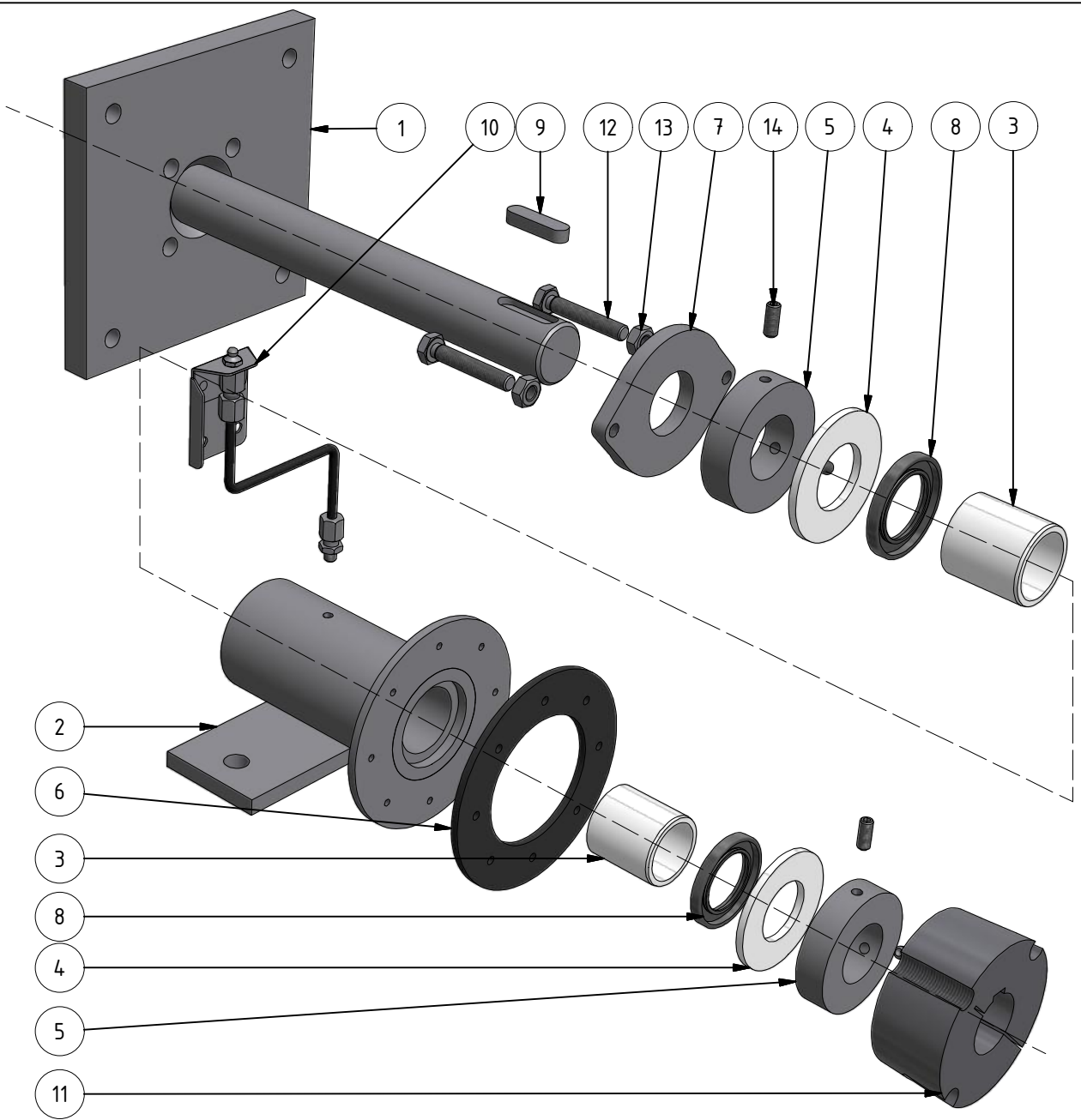

14	4	Screw	A4	MSK6SS M8x20	Art. no. 352120			
13	2	Nut	A4	M6M M10	Art. no. 350130			
12	2	Screw	A4	M6S M10x60H	Art. no.			
11	1	Cone for chain wheel		3020 Ø40	Art. no. 1001273			
10	1	Grease fittings			Drw. no. 2408			
9	1	Key steel		12x8x45	Art. no. 424020			
8	2	Shaft seal		Ø40xØ62x7	Art. no. 1006088			
7	1	Axial retaining washer			Drw. no. 3498_p1			
6	1	Cellular rubber seal			Drw. no. 2307 pos. 1			
5	2	Retaining ring			Drw. no. 0674 -Ø40			
4	2	Axial bearing		Ø40xØ80x5	Art. no. 425725			
3	2	Radial slide bearing			Drw. no. 0580_p3			
2	1	Bearing house			Drw. no. 1138			
1	1	Center shaft			Drw. no. 0717			
Pos no	Qty	Name	Material	Dimension	Remark			
Designer	Drawn by	Projection method 	Controlled by	Stand. ISO 2768-m	Approved	Scale	Sheet size A4	Replaced by
							Sheet 1 / 1	Date
							Draw. no. 4828	Edition A

SERVICE

HDF1201/4-1F-1H

HDF1201/4-2F-2H

Checklist / service report

To be done on every visit

Check backwash pressure

Remarks:

Check panels for damage

Remarks:

Visually inspect the inside of the unit

Remarks:

Check the nozzles for clogging

Remarks:

Lubricate all grease points of the unit

Remarks:

Check drive chain tension

Remarks:

Visually inspect the outside of the unit, clean if needed

Remarks:

Veolia Water Technologies AB

Hydrotech



Mejselgatan 6, 235 32 Vellinge, Sweden
Phone +46 40 42 95 30, Fax. +46 40 42 95 31
mailto:mailbox@hydrotech.se
www.hydrotech.se

SERVICE

HDF1201/4-1F-1H

HDF1201/4-2F-2H

To be done on yearly visit

Check oil condition in drive unit according to separate manual

Remarks:

Check drum bearings for ware

Remarks:

Check shaft gaskets for ware

Remarks:

Check inlet gasket for ware

Remarks:

Check support wheels for ware

Remarks:

Veolia Water Technologies AB

Hydrotech



Mejselgatan 6, 235 32 Vellinge, Sweden
Phone +46 40 42 95 30, Fax. +46 40 42 95 31
mailbox@hydrotech.se
www.hydrotech.se

SERVICE

HDF1201/4-1F-1H

HDF1201/4-2F-2H

To be done every five years

Replace the parts from service kit

Ok

<input type="checkbox"/>	Key steel
<input type="checkbox"/>	Slide bearing
<input type="checkbox"/>	Shaft sealing radial
<input type="checkbox"/>	Spacer 90/50x5 mm
<input type="checkbox"/>	Grease nipple, M8x1mm
<input type="checkbox"/>	Manometer 0-16 bar 1/4" SI
<input type="checkbox"/>	Rubber lip for solids tray
<input type="checkbox"/>	Offset link 1"
<input type="checkbox"/>	Chain lock 1"
<input type="checkbox"/>	Chain wheel Z=32 1" for cone
<input type="checkbox"/>	Cone to chain wheel 3020-Ø40
<input type="checkbox"/>	Cone to chain wheel 3002- Ø50
<input type="checkbox"/>	Chain wheel 1" 10 Ø30
<input type="checkbox"/>	Rubber lip seal HDF1200
<input type="checkbox"/>	Support wheel type 14

Check and if needed replace strategic and critical parts

OK

<input type="checkbox"/>	Nozzles	Qty: _____
<input type="checkbox"/>	Panels	Qty: _____
<input type="checkbox"/>	Drive unit	
<input type="checkbox"/>	Backwash pump	

Remarks:

Veolia Water Technologies AB

Hydrotech



Mejselgatan 6, 235 32 Vellinge, Sweden
Phone +46 40 42 95 30, Fax. +46 40 42 95 31
mailto:mailbox@hydrotech.se
www.hydrotech.se